

Guidelines for the Capture, Handling, Scientific Study, and Salvage of
the Salish Sucker (*Catostomus* sp.)



October 2015

Mike Pearson PhD RP Bio
Pearson Ecological
Agassiz, BC

Disclaimer

An earlier version of this document was prepared in cooperation with members of the Recovery Team for Non-Game Freshwater Fish Species¹ (BC) in 2008. Individual members of the team at that time were:

Jordan Rosenfeld, BC Ministry of Environment, (co-chair)
Karen Calla, Fisheries and Oceans Canada, (co-chair)
Todd Hatfield, Solander Ecological Research, (coordinator)
Don McPhail, Department of Zoology (emeritus), University of British Columbia
Mike Pearson, Pearson Ecological
John Richardson, Department of Forest Sciences, University of British Columbia
Dolph Schluter, Department of Zoology, University of British Columbia
Eric Taylor, Department of Zoology, University of British Columbia
Paul Wood, Department of Forestry, University of British Columbia

This document was intended to guide capture, handling, scientific study, and salvage activities likely to impact Salish Sucker. It does not necessarily represent the views of all individual members of the recovery team, or the official positions of the organizations with which the individual team members were associated.

Dr. Mike Pearson updated these guidelines in 2013, and again in 2015. They are based on the best available knowledge and are subject to modifications resulting from new findings and revised objectives.

¹This recovery team is no longer in existence.

Table of Contents

1	Introduction.....	1
2	Background.....	1
3	Salish Sucker Identification.....	2
3.1	<i>Species Description</i>	2
3.2	<i>Similar Species</i>	3
4	General Guidelines for all Activities	5
4.1	<i>Equipment Sterilization</i>	5
4.2	<i>Riffle Disturbance</i>	5
4.3	<i>Coordination</i>	5
4.4	<i>Timing</i>	5
5	Capturing the Salish Sucker	6
5.1	<i>Trapping - General</i>	6
5.2	<i>Feddes Trapping - Adults and Yearlings</i>	6
5.3	<i>Gee Trapping - Young-of-the-year (Fry)</i>	6
5.4	<i>Seining</i>	6
5.5	<i>Electrofishing</i>	6
6	Handling the Salish Sucker.....	7
7	Scientific Study of the Salish Sucker	7
7.1	<i>Mark-Recapture with Elastomer Injections</i>	7
7.2	<i>Lethal Sampling</i>	8
8	Salvage of the Salish Sucker	8
	APPENDIX 1: HOW TO BUILD A FEDDES TRAP	10
	Materials List	10
	Construction.....	11
	APPENDIX 2: HABITAT TYPE MAPS FOR SALISH SUCKER STREAM REACHES	13

1 Introduction

Section 32 of Canada's *Species at Risk Act (SARA)* prohibits (among others) the killing, harming, harassing, capturing, taking, collecting, or possessing of the Salish Sucker (*Catostomus* sp.), a species listed on Schedule 1 of SARA as Endangered. If your activity may impact the Salish Sucker in one of the ways mentioned above, a permit under SARA may be required to comply with the Act. The onus is on you to ensure your activities comply with SARA.

This document provides advice for the capture, handling, scientific study, and salvage of the Salish Sucker. The guidelines herein are intended to minimize harm to the Salish Sucker, and are considered the best practices for capture, handling, scientific, study, and salvage of the Salish Sucker. By following these guidelines, acute mortality of Salish Sucker as a result of trapping should be <1%.

Please refer to <http://www.dfo-mpo.gc.ca/species-especes/permits-permis/permits-eng.htm> for further information on SARA permitting for aquatic species at risk.

2 Background

The Salish Sucker is a small freshwater fish found in 11 Canadian watersheds, all in British Columbia's Fraser Valley (Figure 1). Its global distribution includes at least four additional populations in northwestern Washington State.

Adults are most abundant in headwater marshes and beaver ponds. Juveniles are most often found in shallow pools or glides containing cover. One, or a very few sites, may contain the great majority of individuals in a watershed. Aquatic invertebrates form most of their diet.

Salish Sucker populations are sampled regularly for scientific study and monitoring of habitat restoration. At existing low levels of intensity, such activities are unlikely to impact populations. The Salish Sucker is also regularly captured and relocated during fish salvage operations for in-stream works. The impact of activities is likely proportional to the number of individuals affected, and is more significant if long sections of channel are affected at once, or if fish are translocated out of an area supporting high densities, and into less favourable habitats supporting lower Salish Sucker densities.

For additional background information on the Salish Sucker, please refer to the *Recovery Strategy for the Salish Sucker (Catostomus sp.) in Canada [Proposed]*² (Fisheries and Oceans Canada 2012).

² http://www.sararegistry.gc.ca/document/default_e.cfm?documentID=1942

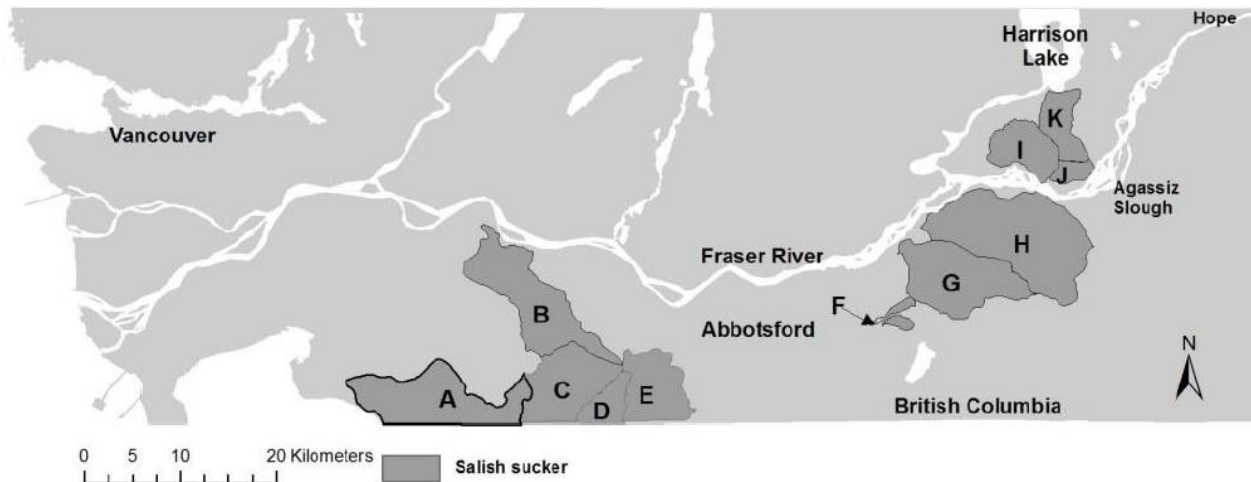

Figure 1. Watersheds known to support the Salish Sucker in British Columbia: A. Little Campbell River; B. Salmon River; C. Bertrand Creek; D. Pepin Creek; E. Fishtrap Creek; F. Salwein Creek/Hopedale Slough; G. Chilliwack Delta; H. Elk Creek/Hope Slough; I. Mountain Slough; J. Agassiz Slough; K. Miami River.

3 Salish Sucker Identification

3.1 Species Description

The Salish Sucker is a small (<21 cm males, <28 cm females) fine-scaled freshwater fish in the sucker family. The back is grey or green with black mottling that extends down the flanks. The mouth is small (approximately equal in diameter to the eye), fleshy-lipped and located on the bottom of the head. The Salish Sucker has 9-10 dorsal fin rays (this is the best field indicator for adults) and the length of the dorsal fin insertion is less than 2 times the caudal peduncle depth (this is the best field indicator for juveniles <100 mm). The lateral line has > 90 scales. Fish larger than 100 mm can be sexed in the field using differences in the anal fin (Figure 2). A broad, red to purplish-red band forms on the flanks (Figure 2) during the spawning season (early March to early July), and females' underbellies may appear swollen due to developing eggs.

A *Field key to the Freshwater Fishes of British Columbia* can be downloaded at: <http://www.zoology.ubc.ca/~etaylor/nfrg/fresh.pdf>. For additional information on the description of the Salish Sucker, please refer to the *Recovery Strategy for the Salish Sucker (Catostomus sp.) in Canada [Proposed]*³ (Fisheries and Oceans Canada 2012).

³ Ibid.



Figure 2. Female and male Salish Suckers.

3.2 *Similar Species*

The Largescale Sucker (*Catostomus macrocheilus*) is the only other sucker species commonly found with the Salish Sucker (Figure 3). It grows to larger size (>350 mm), has more than 12 dorsal fin rays, and larger scales (< 75 on the lateral line).

The Mountain Sucker (*Catostomus platyrhynchus*) is occasionally caught in some Salish Sucker watersheds, such as slough reaches close to the Fraser River. Although similar in size to the Salish Sucker, the Mountain Suckers has much fleshier lips, distinctly notched at the corners of the mouth.



Figure 3. Clockwise starting from top left: Salish Sucker; comparison between the Salish Sucker and Largescale sucker; spawning colouration; late summer colouration.

4 General Guidelines for all Activities

4.1 Equipment Sterilization

To prevent the spread of invasive species and disease organisms, sterilize all gear and equipment with a 1% bleach solution prior to moving gear from one waterbody to another. This includes but is not limited to: waders, traps, nets, holding containers and measuring equipment.

4.2 Riffle Disturbance

Always take care not to disturb riffles, as they provide habitat to eggs and hatchlings. This may be achieved by avoiding reaches that contain riffle habitat altogether, navigating alongside banks of riffle habitat, or avoiding electrofishing within 10 m of riffle habitat.

4.3 Coordination

If activities are planned to occur within the same area and timeframe by multiple permit holders, DFO may request coordination of activities. This is intended to minimize potential repeated harm to the species.

4.4 Timing

Work windows are one of many measures used to protect fish and fish habitat, and are considered when issuing permits under SARA. The work windows for activities in various habitat types for the Salish Sucker⁴ (to determine the habitat type for a given stream reach, refer to Appendix 1) are as follows:

Table 1. Work windows and special conditions for activities in different categories of Salish Sucker habitat.

	Mar	Apr	May	Jun	Jul	Aug	Sep	Oct
Least risk window for projects near water in spawning reaches.								
Least risk window for projects near water in critical habitat and potential/confirmed presence reaches.								
Least risk window for projects near water in potential/confirmed winter presence reaches.								
During this period handle gravid females in such a way that minimizes damage to, or expulsion of, eggs.								

⁴During this period other species such as salmonids might be present in proposed work areas during sensitive life stages. It is your responsibility to ensure you avoid causing serious harm to fish in compliance with the *Fisheries Act*. For more information, please refer to DFO's Projects Near Water website <http://www.dfo-mpo.gc.ca/pnw-ppe/index-eng.html>.

5 Capturing the Salish Sucker

5.1 Trapping - General

- Feddes or Gee trapping is the preferred method for capturing the Salish Sucker.
- The Salish Sucker is rarely caught at temperatures below 6 °C.⁵
- Bait traps with roe and/or dried cat food.
- If daytime dissolved oxygen concentration (DO) is below 4 mg/L traps must be suspended to provide fish with access to the water's surface.
- Orient traps parallel to the current.
- Catches will be highest in overnight sets.
- Account for traps at all times; forgotten traps may continue to capture and kill fish even when not baited.
- Lift traps within six to 24 hours; or, if daytime dissolved oxygen concentration (DO) is below 4 mg/L, limit sets to 2-6 hours during daylight hours.

5.2 Feddes Trapping - Adults and Yearlings

- Set Feddes traps (see Appendix 1 for details on construction) in water at least 70 cm deep, preferably near aquatic vegetation or other cover.
- Target the deepest available water.

5.3 Gee Trapping - Young-of-the-year (Fry)

- Set Gee traps in shallow (<50 cm) pools or slow glides with abundant aquatic vegetation.

5.4 Seining

- Seining may be difficult and ineffective due to deep water and abundant obstructions.
- To beach seine, pull the seine net (with floats on top and weights on the bottom) together from each end to encircle fish.
- To kick seine, flush fish into a small pole seine by manually disturbing the substrate immediately upstream of the net.

5.5 Electrofishing

- Electrofishing is not recommended (except for fish salvage operations; refer to Section 8).
- Electrofishing in Salish Sucker habitat may be ineffective due to deep water and poor visibility.

⁵ Pearson and Healey (2003) found the highest catch per unit effort in Pepin Brook marsh coincided with temperatures between 12 and 15 °C (<http://www.bioone.org/doi/abs/10.1643/IA02-237.1>).

6 Handling the Salish Sucker

- Minimize handling time to the extent possible.
- Handle the Salish Sucker with wet hands free of sunscreen, insect repellent or other potential irritants.
- Lightly anaesthetize the Salish Sucker to be measured or marked in a solution⁶ of MS222 (tricaine methanosulfonate; typically 70 mg/L).⁷
- During the spawning season (early March to early July) handle gravid females in such a way that minimizes damage to, or expulsion of, eggs.
- After handling, allow the Salish Sucker to recover in a holding container with fresh stream water, changed frequently to maintain temperature and oxygen close to ambient levels.
- Keep any holding containers a minimum of 10 m away from any electrofishing.
- Check condition of held Salish Sucker (including normal respiration) at least once every 15 minutes; or, if air or water temperature exceeds 20 °C, check condition at least once every 5 minutes.
- Following recovery, release the Salish Sucker at the original point of capture (except in salvages; refer to Section 8).

7 Scientific Study of the Salish Sucker

7.1 Mark-Recapture with Elastomer Injections

- Elastomer injections are recommended for short term mark-recapture studies, but not for long term studies as marks are difficult to detect after one field season.
- Subcutaneous injections of elastomer (Northwest Marine Technologies, Shaw Island, WA) are simple to use, inexpensive, and relatively non-invasive.
- Insert the needle approximately 1 cm anterior to the fin insertion and slide it, just under the skin, posteriorly to the



Figure 4. The Salish Sucker may be marked with subcutaneous injections of coloured elastomer.

⁶ Soft waters may require buffering with sodium bicarbonate.

⁷ Dosage may vary as efficacy is affected by body size, density of fish, and water quality. Anaesthesia is achieved once equilibrium, muscle tone, and spinal reflexes are lost, while regular opercular movements are maintained.

mark site (Figure 4).

- The best mark locations are at the base of the paired fins, where the skin is translucent over bone.

7.2 Lethal Sampling

- At this time, intentional lethal sampling is only appropriate for the collection of voucher specimens to document newly discovered populations.
- To lethally sample the Salish Sucker, overdose the fish in anaesthetic (approximately 70 mg/L MS 222 solution or greater)⁸ and preserve it in 95% ethanol.
- Retain a minimum of one and a maximum of two individuals for deposit with the Beaty Biodiversity Museum⁹ and/or the Royal British Columbia Museum.¹⁰

8 Salvage of the Salish Sucker

Conduct a fish salvage and re-location if the Salish Sucker is at risk of harm from proposed works (this includes most instances of machinery work in waters where the species may be present) using the following sequential steps. Refer to Section 4.4 to ensure you comply with the appropriate work window.

- A.** Attempt to clear Salish Sucker from the area (without capture).
 - i.** Install a stop net (0.25 in mesh or finer) at one end of the section to be isolated.
 - ii.** Starting from the installed stop net and working outwards, sweep the channel with a beach or pole seine¹¹ (refer to Section 5.4) to clear it of fish.
- B.** Isolate the site.
 - i.** Install a second stop-net¹² not more than 100 metres from the first stop-net.
- C.** Capture remaining Salish Sucker.
 - i.** Set at least one Feddes trap and one Gee trap¹³ (refer to Sections 5.1 through 5.3) per 10 metres of channel length within the isolated area; or, if sites are not deep enough for Feddes traps, use one Gee trap per five metres of channel length.
 - ii.** Conduct one overnight trapping set; or, if daytime DO is less than 2.5 mg/L, set traps for a minimum¹⁴ of six daylight hours on two consecutive days.
 - iii.** Repeat trapping until no Salish Sucker are captured (this may take several days; using more traps may shorten the time required).
 - iv.** If the enclosed area can be waded, and water temperature is at least 5 °C,

⁸ Dosage may vary as efficacy is affected by body size, density of fish, and water quality. Euthanasia is achieved once opercular movements have ceased, and opercular colouration becomes pink.

⁹ <http://www.beatymuseum.ubc.ca/fish-collection>

¹⁰ <http://royalbcmuseum.bc.ca/nh-collections/ichthyology/>

¹¹ If seining is infeasible, use splashing, physical disturbance and/or short bursts of low-voltage electrofishing.

¹² If a seine was used to clear fish, it can serve as the second stop-net; simply secure the seines' ends to shore at the end of the sweep to form the enclosure.

¹³ Gee traps alone are insufficient; adult Salish Suckers very rarely enter them.

¹⁴ A minimum soak time for trapping (as opposed to a maximum) is described for the salvage protocol because the intention is to remove as many Salish Sucker as possible before a project near water is initiated.

electrofish^{15,16} the reach, and use dip nets to remove Salish Sucker.

- Use a maximum of three backpack electrofisher passes; or, if the habitat is to be destroyed, continue until no Salish Sucker are captured in two consecutive passes.
- Always use the minimum effective voltage of straight DC current or gated bursts of current.

D. Handle the Salish Sucker gently (refer to Section 6).

E. Release¹⁷ the Salish Sucker.

- i.** As they have very small home ranges, following recovery release the Salish Sucker into the closest suitable habitat (within 200 m when feasible), where they are unlikely to be re-captured.

¹⁵ Electrofishing operations may also be subject to DFO restrictions on timing and location to protect salmonids and eggs.

¹⁶ Unlike salmonids, the Salish Sucker rarely rolls belly up when shocked; they usually freeze and sink to the bottom, where they are difficult to see.

¹⁷ Additional legislation may apply to translocations.

APPENDIX 1: HOW TO BUILD A FEDDES TRAP

Materials List

- (Quantity: 2) 51" lengths of 1/2 inch plastic tubing
- (Quantity: 2) 51 1/4 " lengths of 1/2 inch plastic tubing
- (Quantity: 1) 8" piece of 1/2 inch plastic tubing
- (Quantity: 2) T- joint fittings
- (Quantity: 2) straight fittings
- (Quantity: 10) hose clamp rings
- (Quantity: 50) cable ties
- (Quantity: 1) 5 m length of 1/4 inch yellow poly rope
- (Quantity: 1) 32"x56" piece of 1/4" galvanized steel mesh
- (Quantity: 1) Door; 10"x10" piece of 1/2" galvanized steel mesh
- (Quantity: 2) Elasticized bands and wire hooks for door closures
- (Quantity: 4) Steel rods 3/16" by 33"
- (Quantity: 2) Funnels; 32"x14" piece of 1/4" galvanized steel mesh

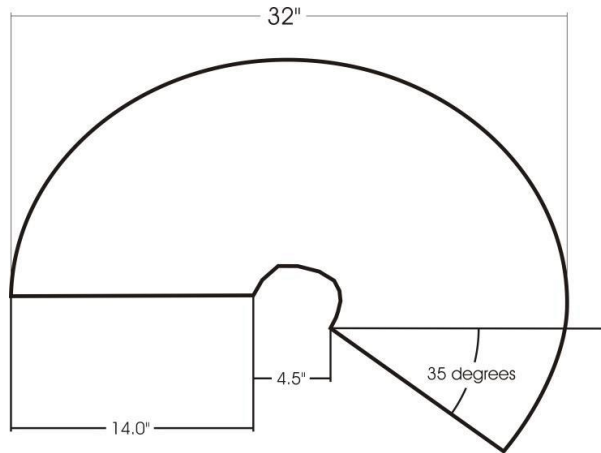

Feddes traps are modeled on Gee minnow traps, but are larger (32" x 16") and are easily constructed of materials available at most hardware stores.

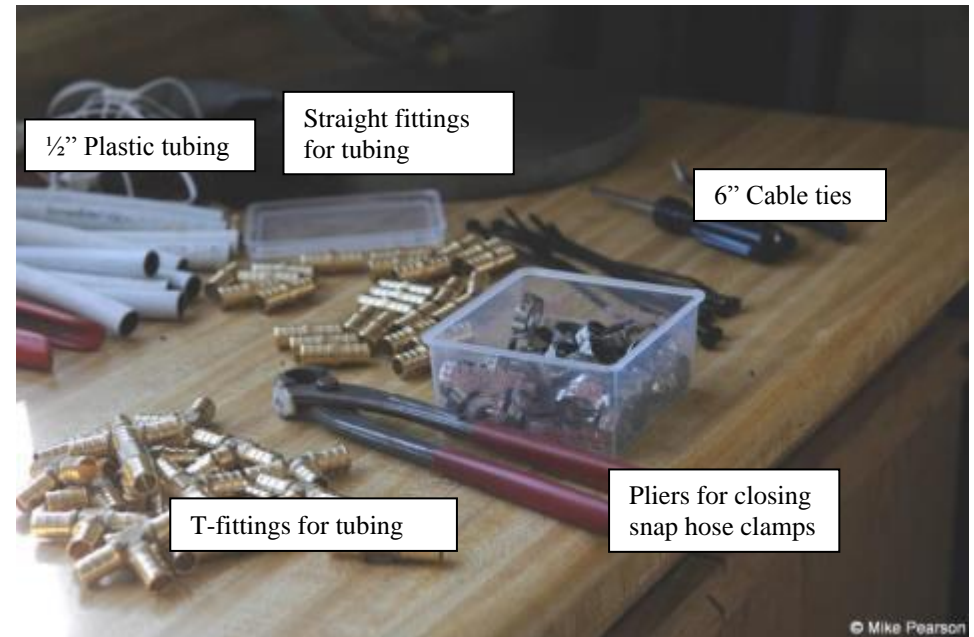

Construction

1. Construct end hoops by joining ends of 51 ¼" lengths with straight fittings secured with snap hose clamps.



2. Assemble funnels by overlapping and securing straight edges with cable ties. Wrap perimeter of funnel mouth around end hoop and secure with cable ties.



3. Assemble central frame by using T-fittings to form 2 hoops of the 51" tubing lengths joined by the 8" cross piece.

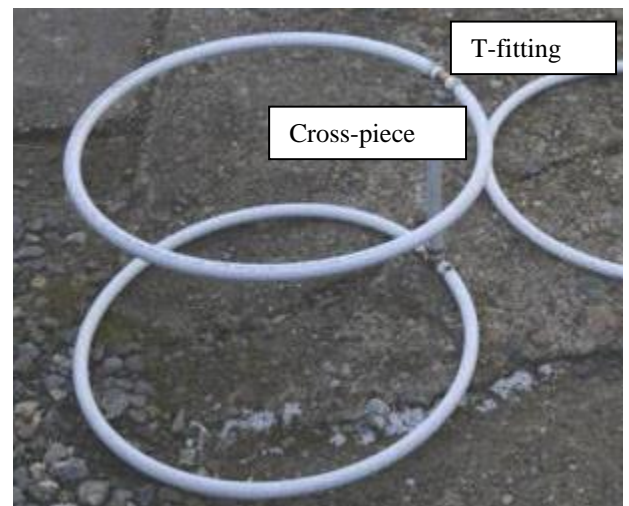

4. Secure the cross piece to the centre of a 32" edge of the large piece of mesh and each funnel to one of the 56" edges.

Roll the large mesh onto the frame securing it well with cable ties.

5. Bend each end of each steel rod 90° in the



same direction $\frac{3}{4}$ inch from each end using a vice.

6. Insert the bent ends of the first rod through the mesh immediately under the funnel hoops to that the rod lines up with the cross piece, and secure it to the outside of the trap with cable ties.
7. Install the other 3 rods evenly spaced around the outside of the trap. They will strengthen it greatly.



8. Cut a door opening extending along the length of the crosspiece and 8" along the inside edges of the middle hoops.
9. Tie the trap retrieval rope to the cross-piece and steel rod.
10. Attach the door to the cross piece using cable ties and affix door closures of elasticized bands (hair elastics) and wire hooks.

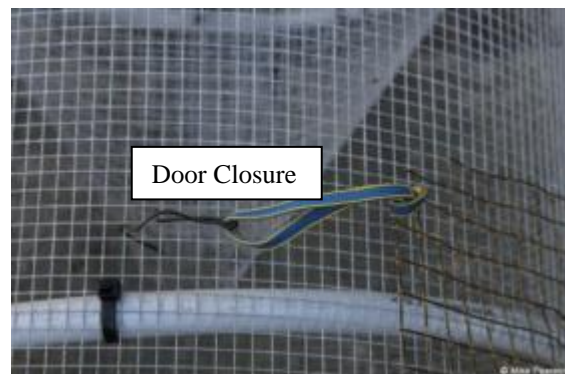
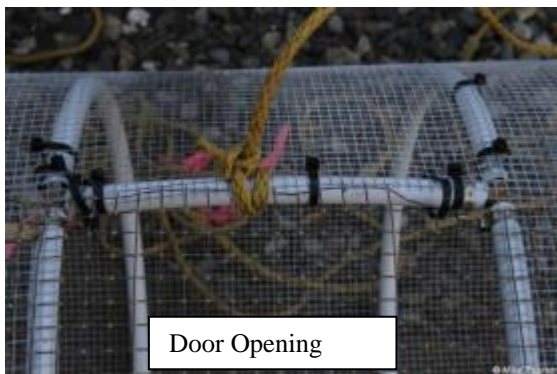

Caution: Songbirds and small mammals readily enter these traps. Prevent unnecessary deaths by fastening doors in the open position when they are stored outside.

APPENDIX 2: HABITAT TYPE MAPS FOR SALISH SUCKER STREAM REACHES

The following maps are intended for concurrent use with Table 1, to determine any associated work windows for a given stream reach. Species presence and habitat types identified on the maps are based on best available information and are subject to change. Uncategorized stream reaches may also support Salish Sucker.

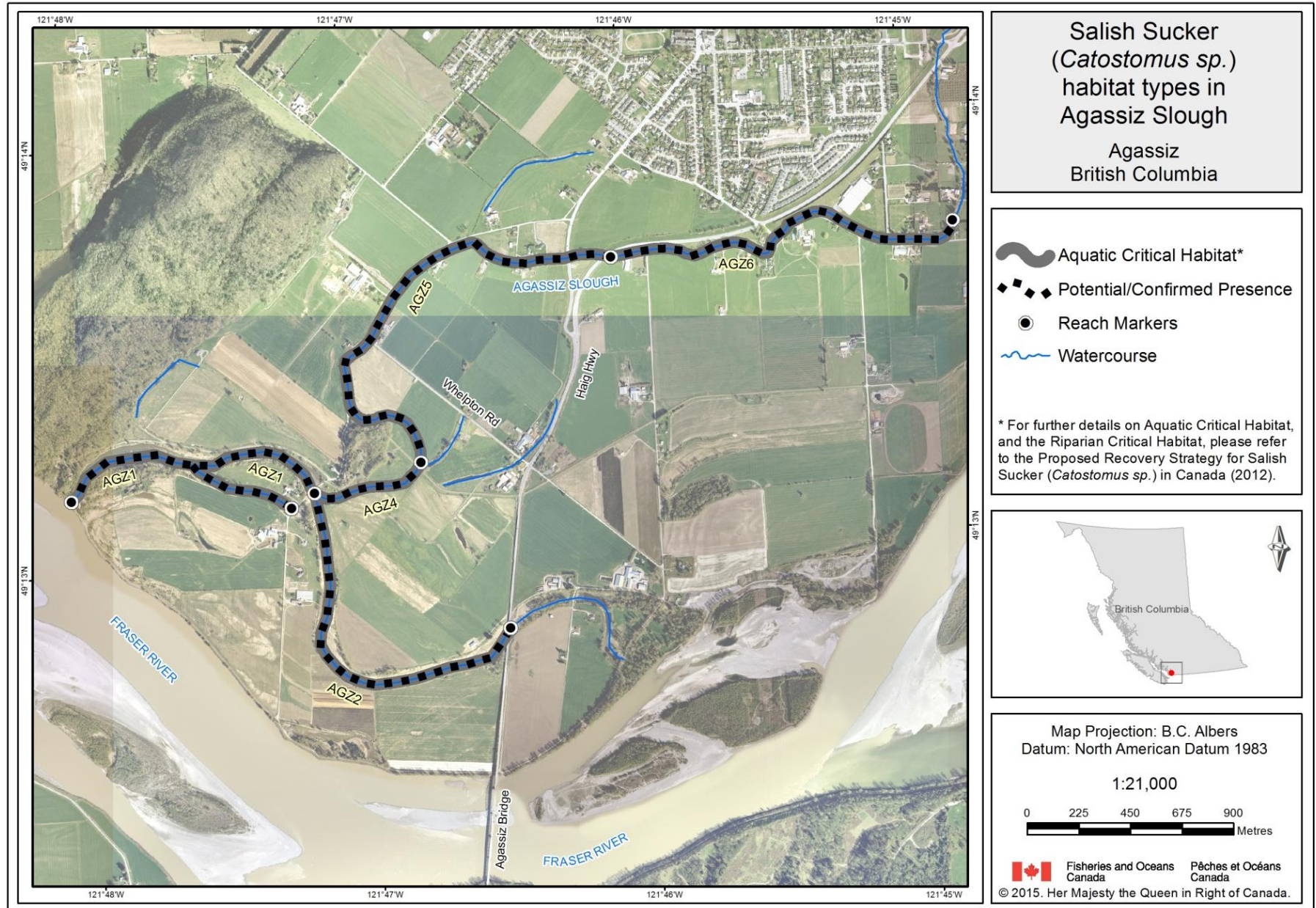

Figure A1. Habitat types for Salish Sucker stream reaches in the Agassiz Slough watershed.

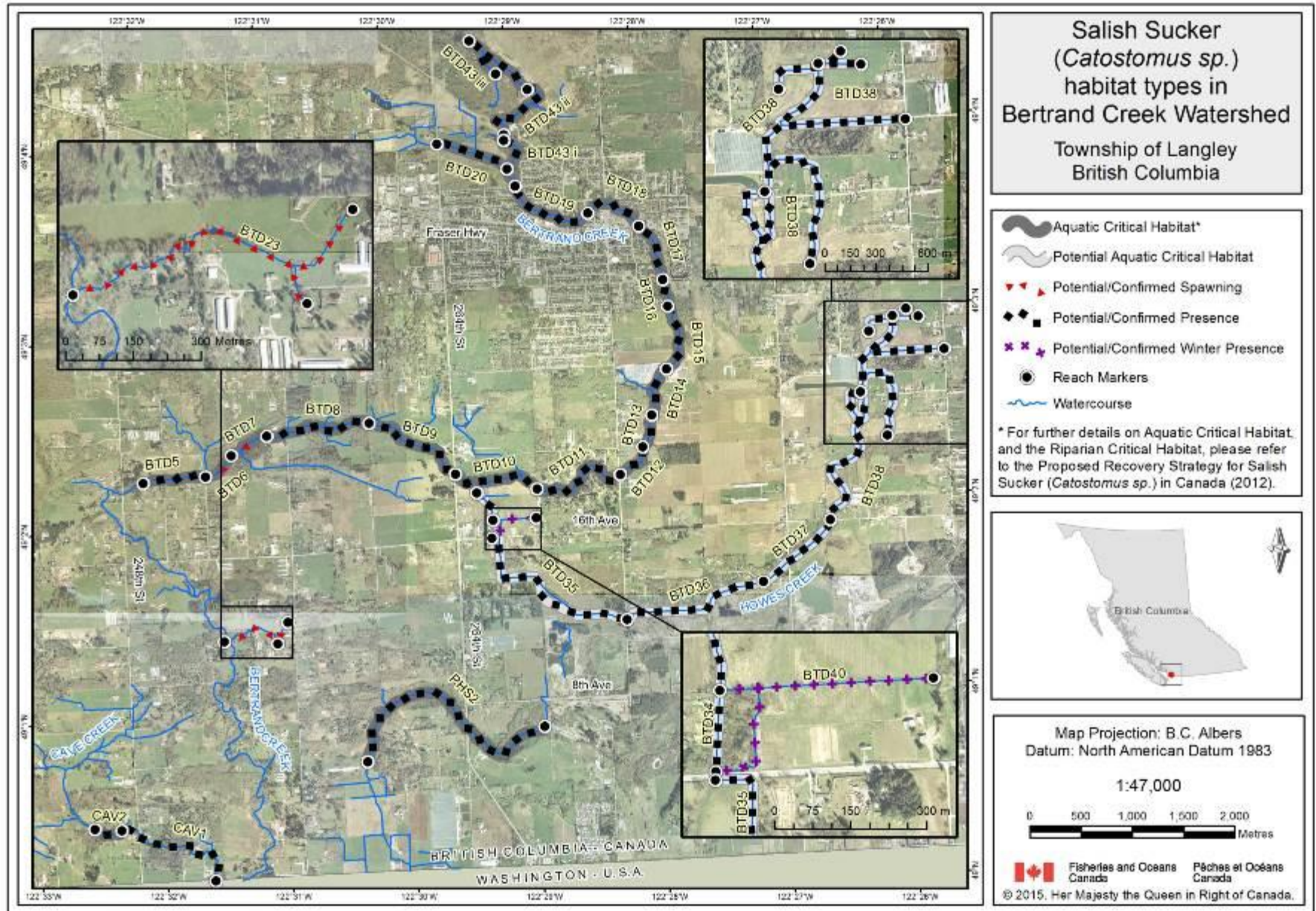

Figure A2. Habitat types for Salish Sucker stream reaches in the Bertrand Creek watershed.

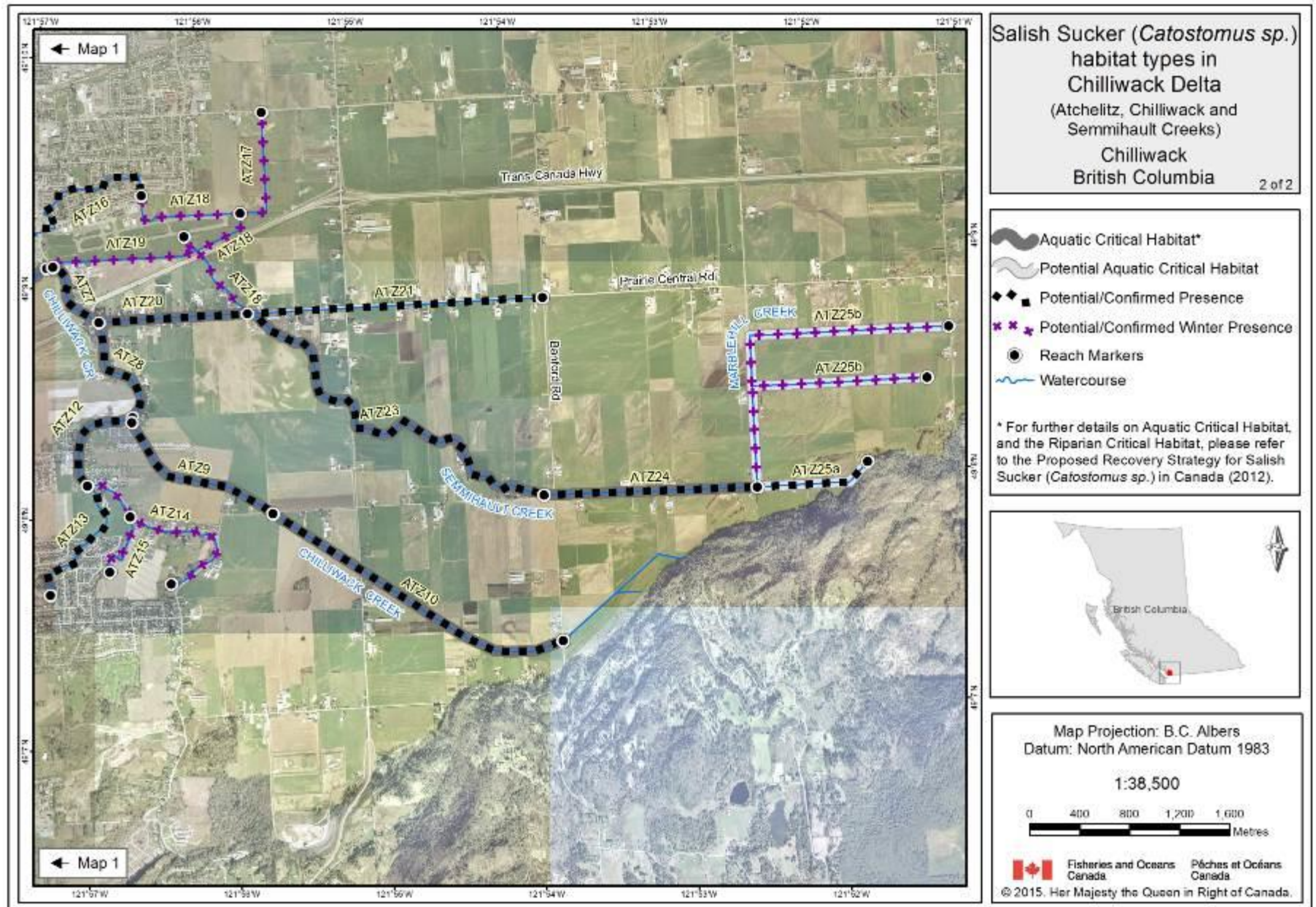

Figure A3. Habitat types for Salish Sucker stream reaches in the Chilliwack Delta watershed.

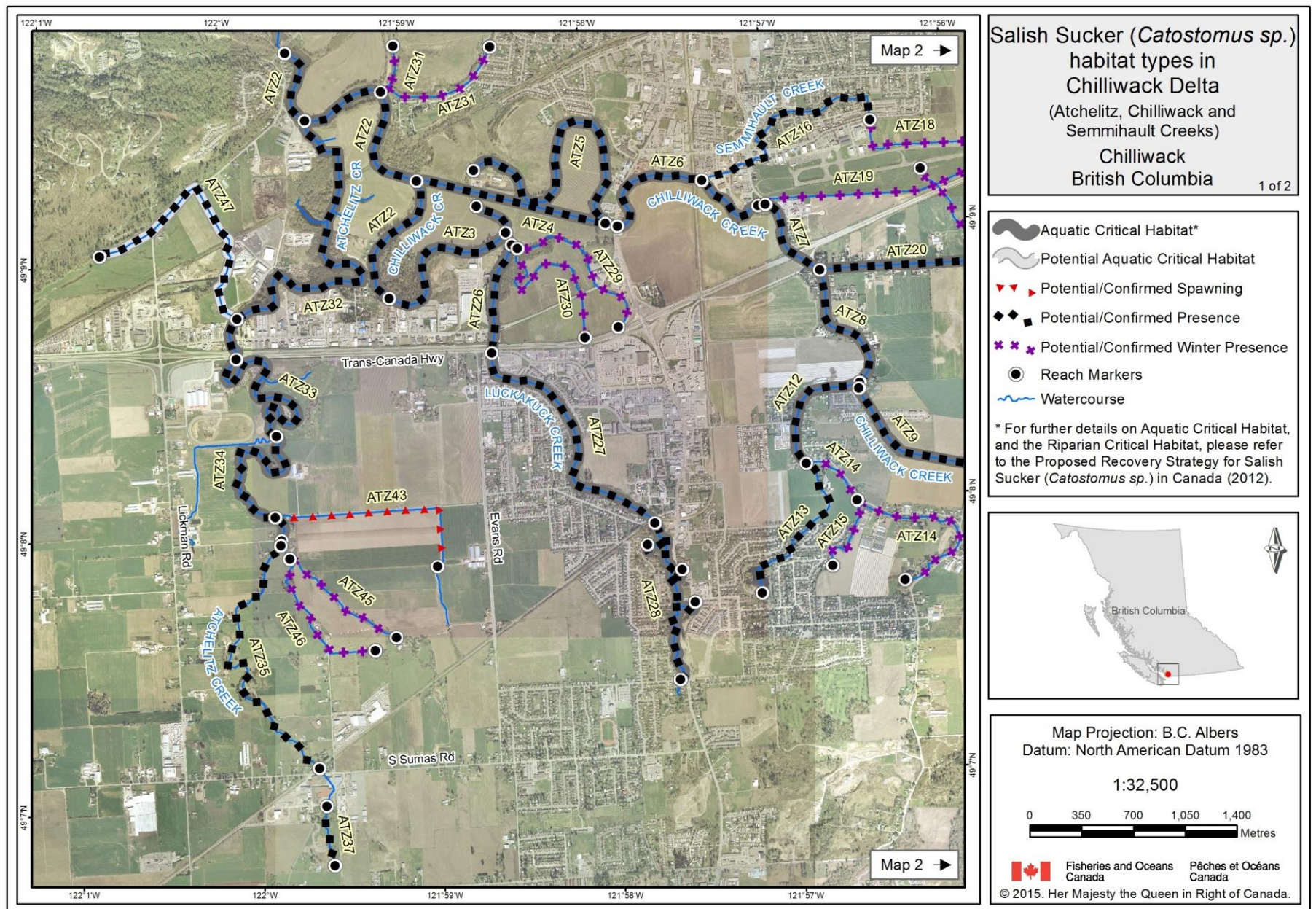

Figure A4. Habitat types for Salish Sucker stream reaches in the Chilliwack Delta watershed (map 1/2).

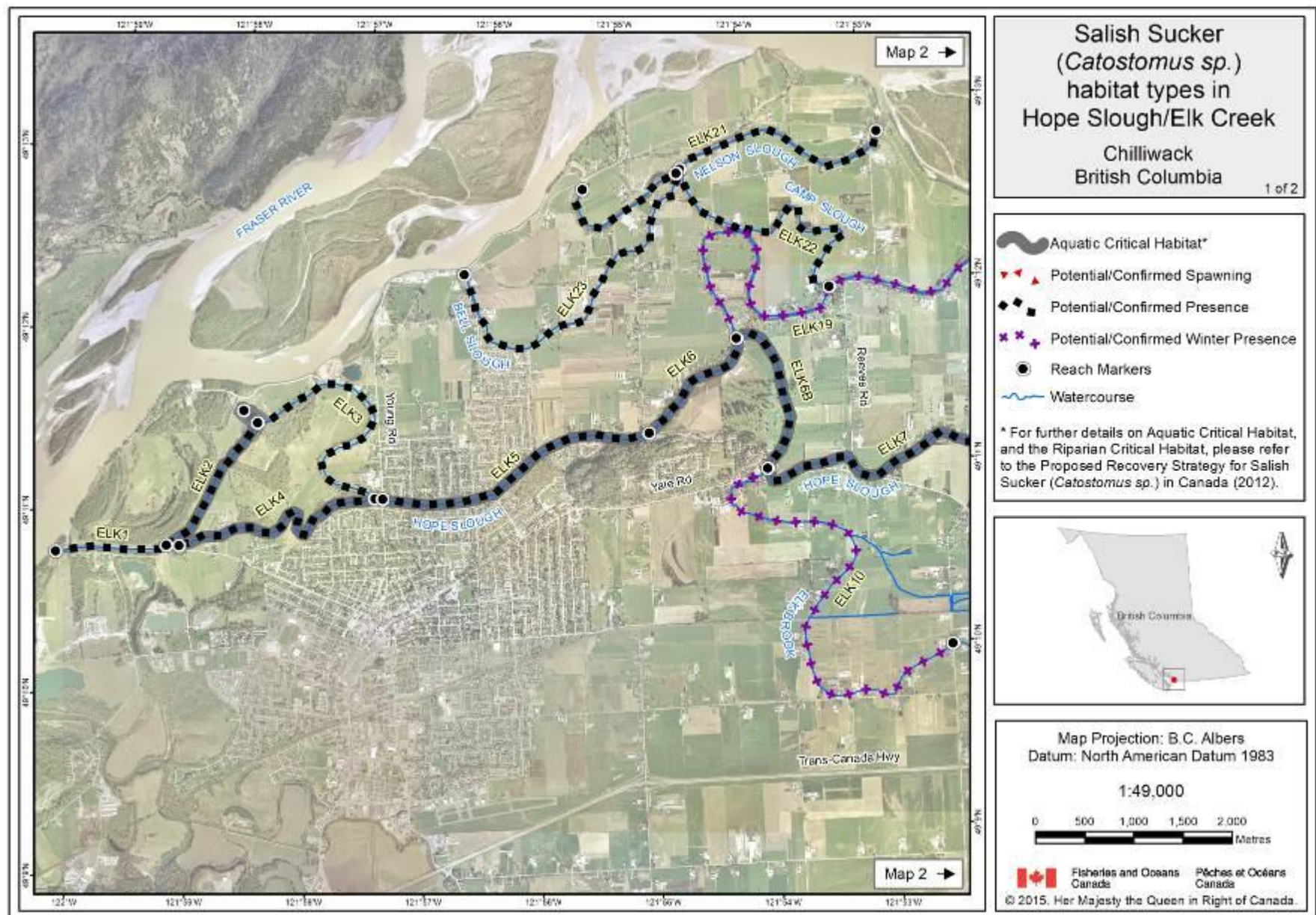

Figure A5. Habitat types for Salish Sucker stream reaches in the Hope Slough/Elk Creek watershed (map 2/2).

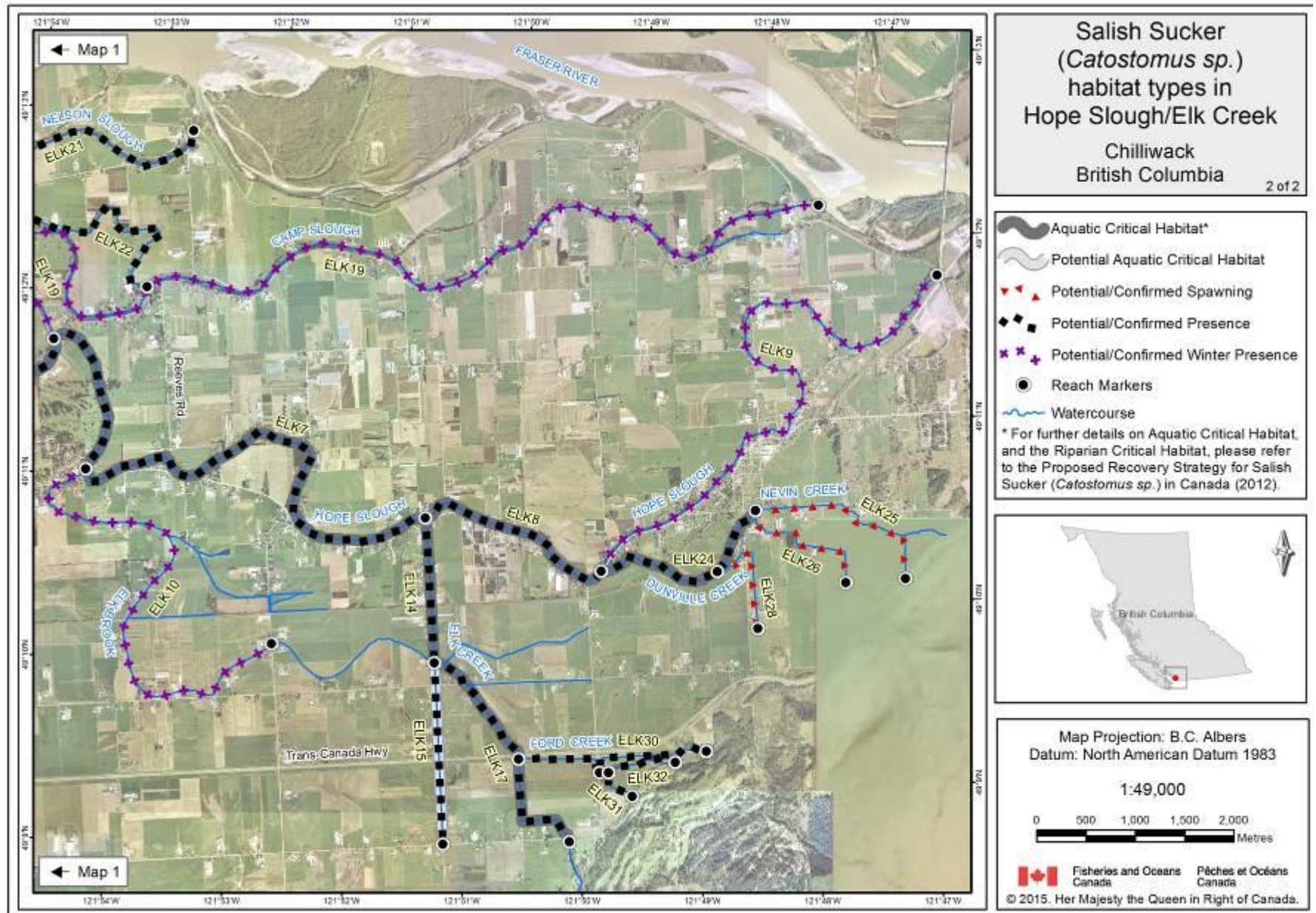

Figure A6. Habitat types for Salish Sucker stream reaches in the Hope Slough/Elk Creek watershed.

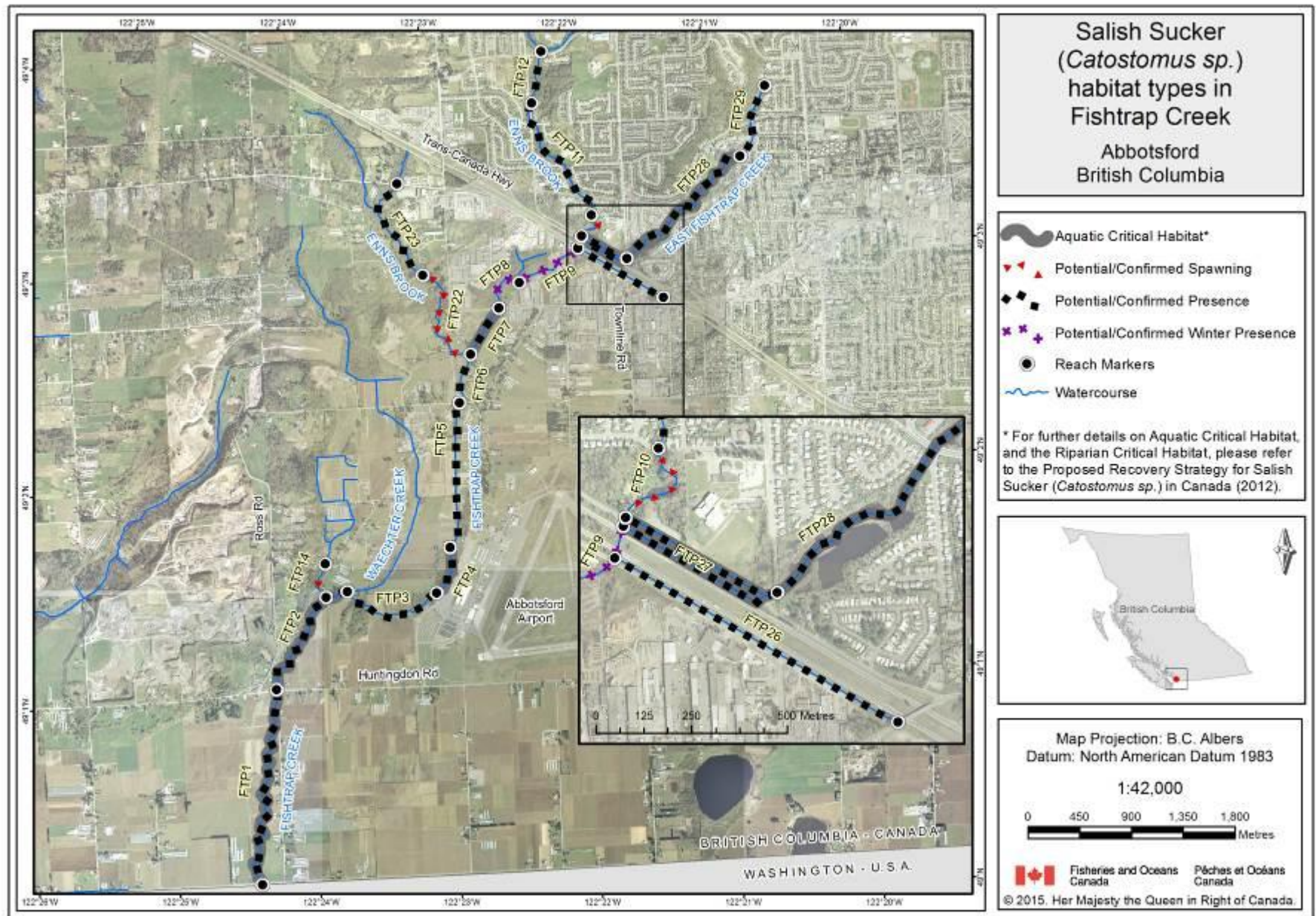

Figure A7. Habitat types for Salish Sucker stream reaches in the Fishtrap Creek watershed.

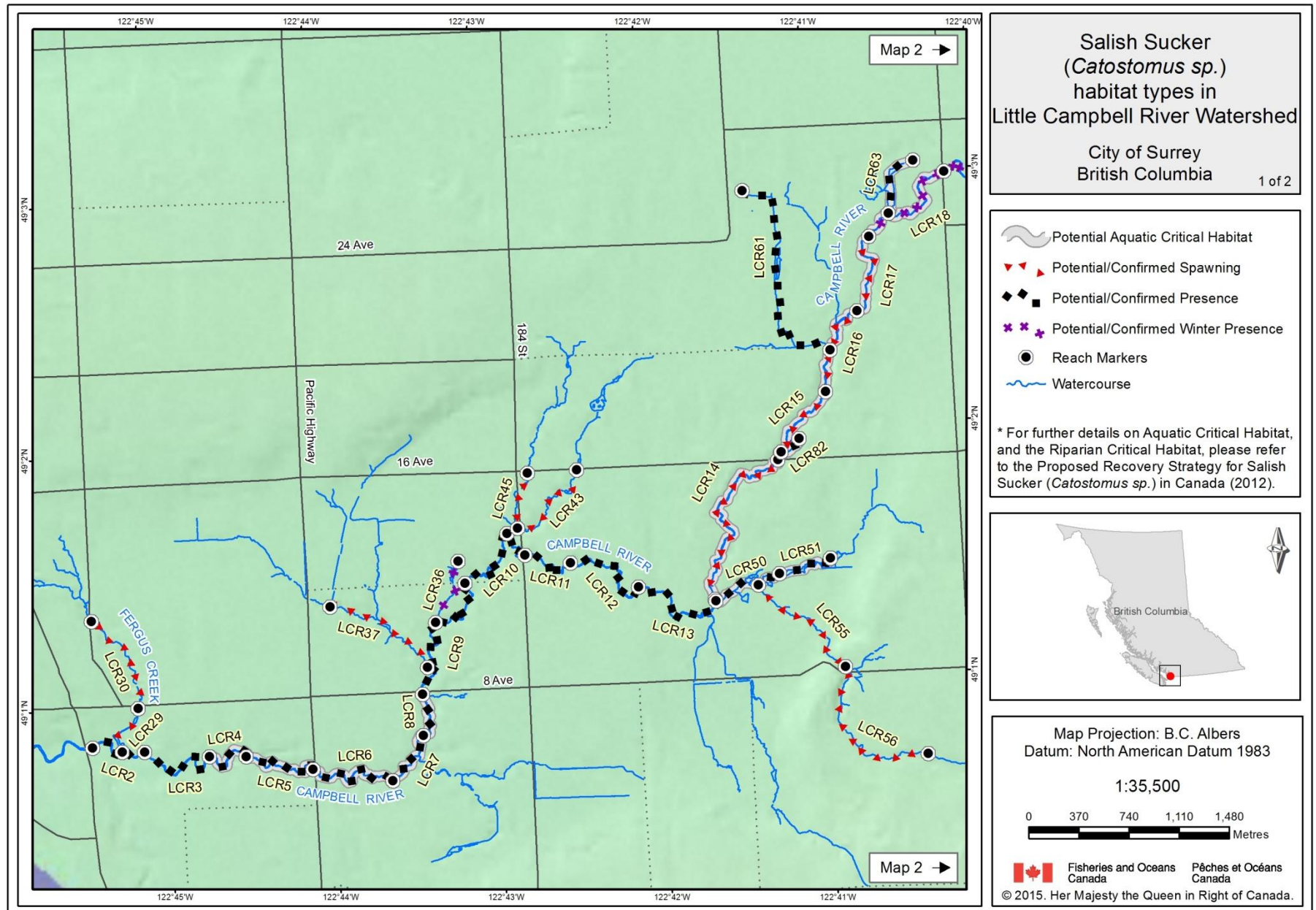

Figure A8. Habitat types for Salish Sucker stream reaches in the Little Campbell River watershed (map 1/2).

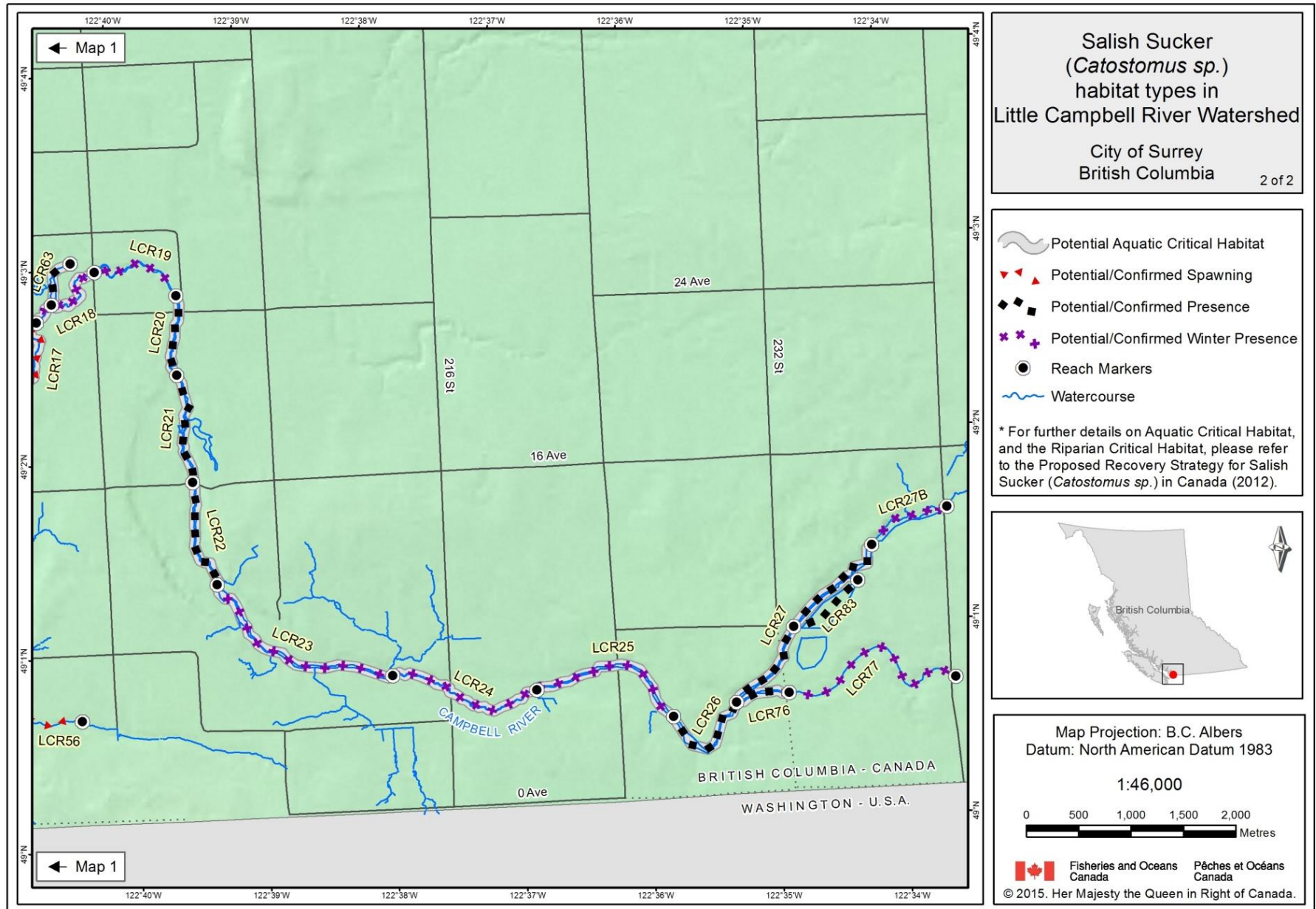

Figure A9. Habitat types for Salish Sucker stream reaches in the Little Campbell River watershed (map 2/2).

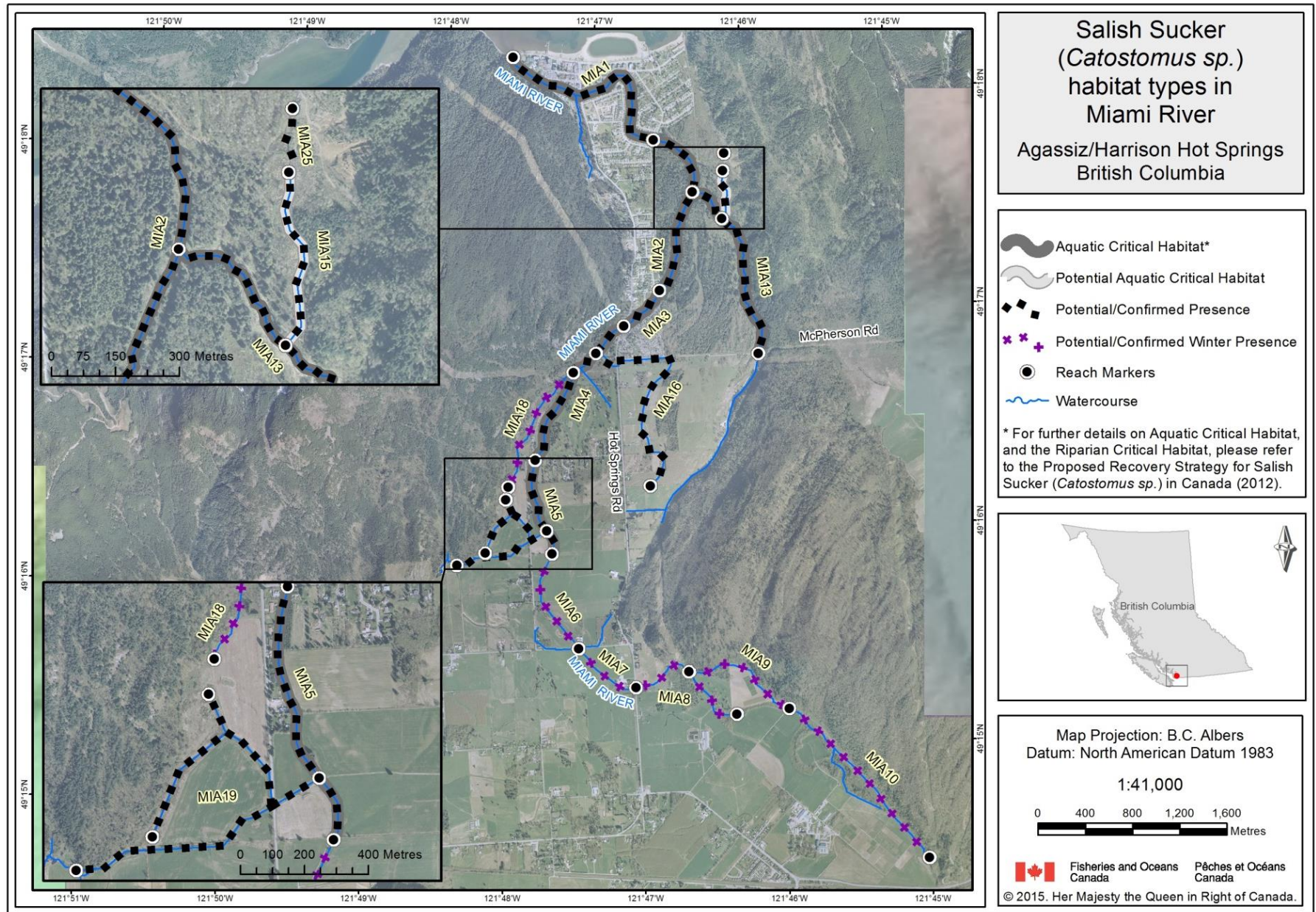

Figure A10. Habitat types for Salish Sucker stream reaches in the Miami River watershed.

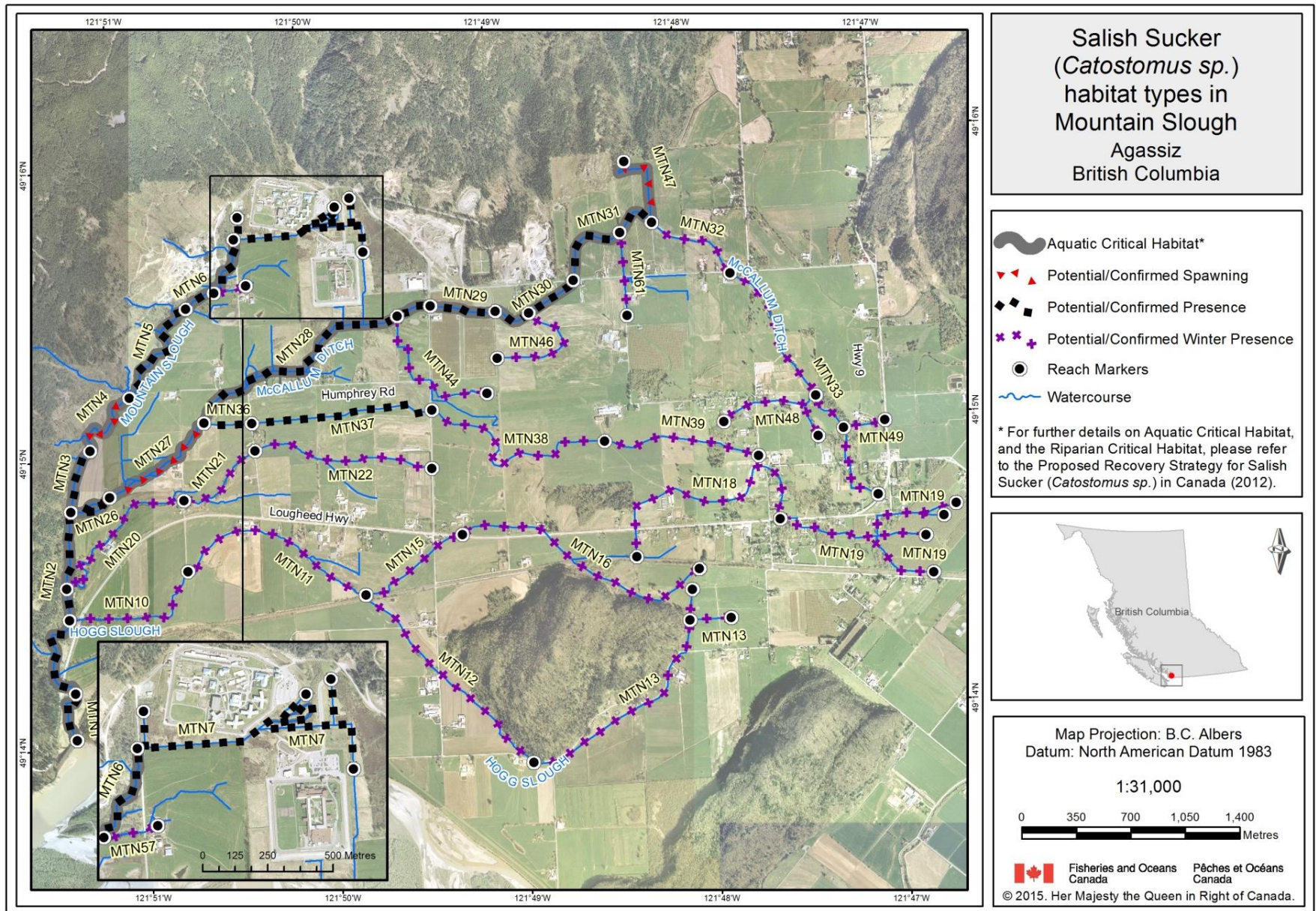

Figure A11. Habitat types for Salish Sucker stream reaches in the Mountain Slough watershed.

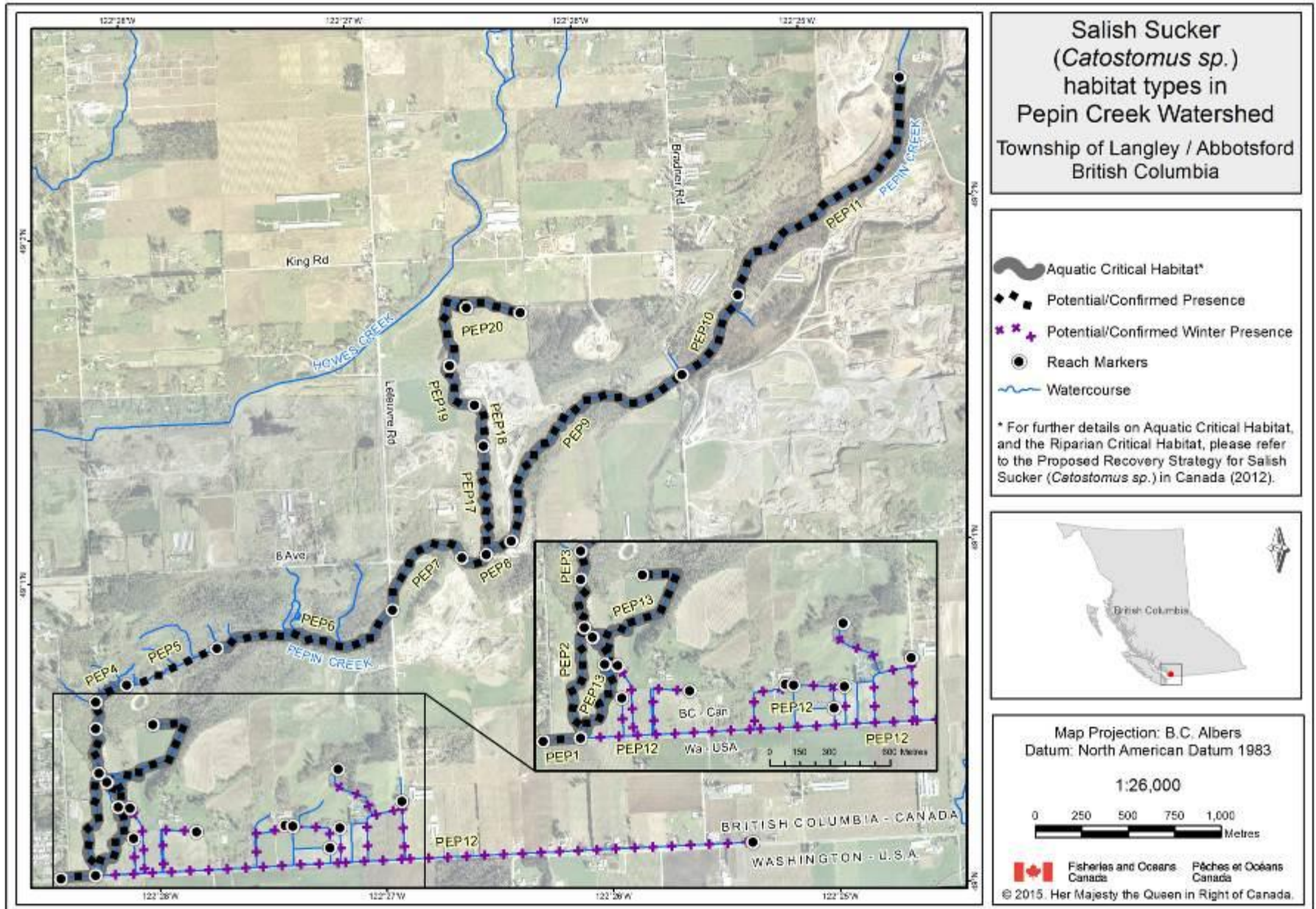

Figure A12. Habitat types for Salish Sucker stream reaches in the Pepin Creek watershed.

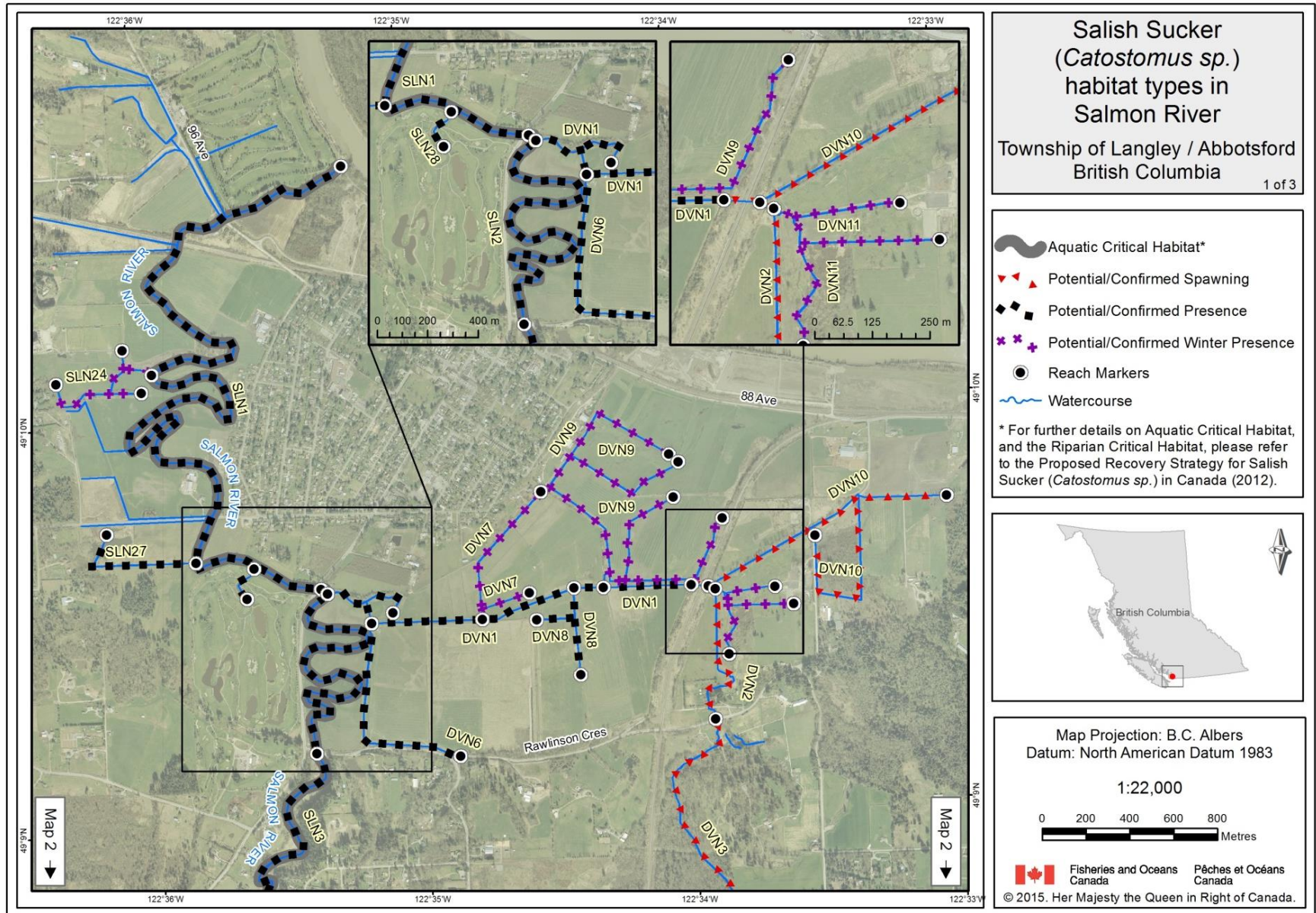

Figure A13. Habitat types for Salish Sucker stream reaches in the Salmon River watershed (map 1/3).

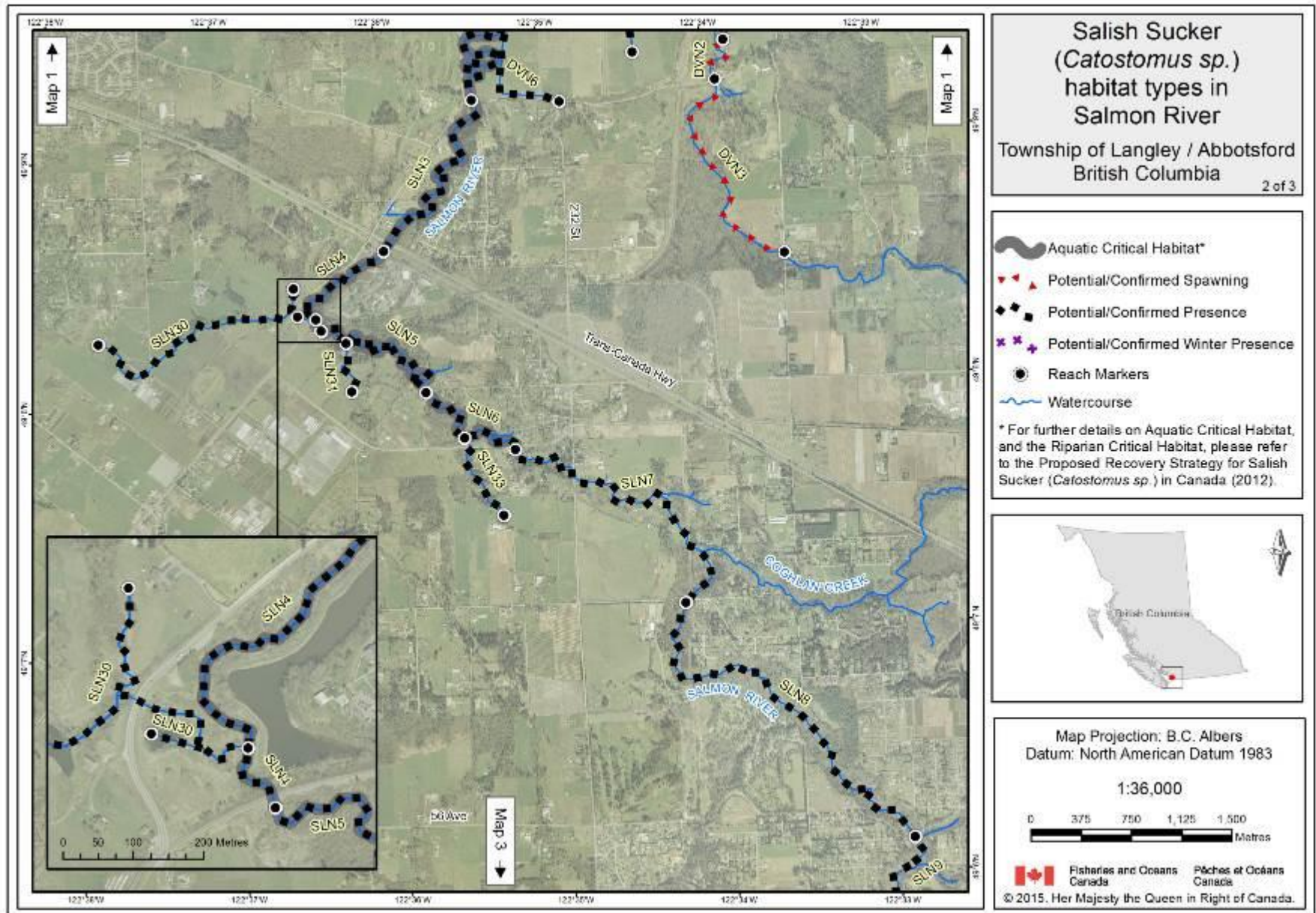

Figure A14. Habitat types for Salish Sucker stream reaches in the Salmon River watershed (map 2/3).

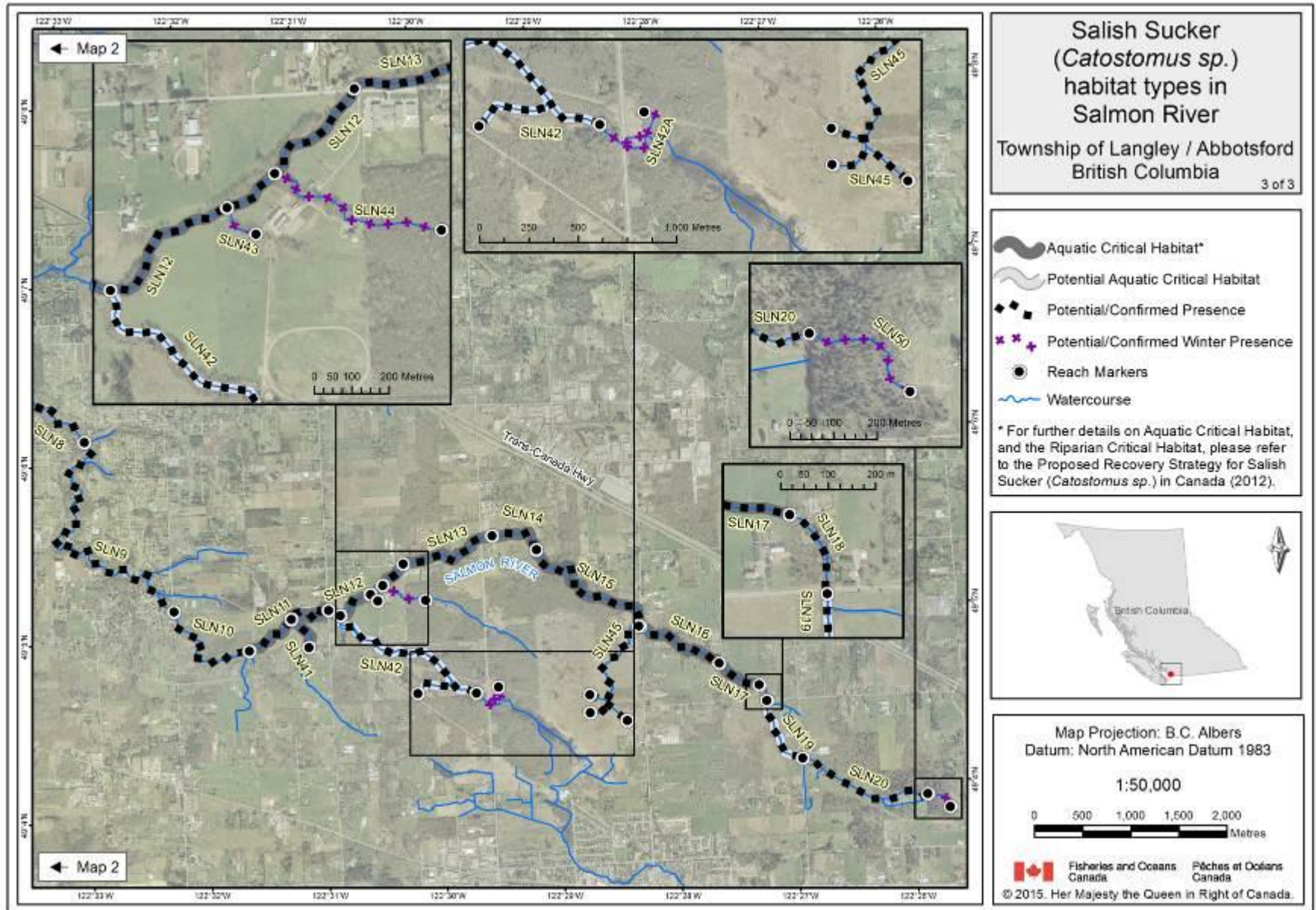

Figure A15. Habitat types for Salish Sucker stream reaches in the Salmon River watershed (map 3/3).

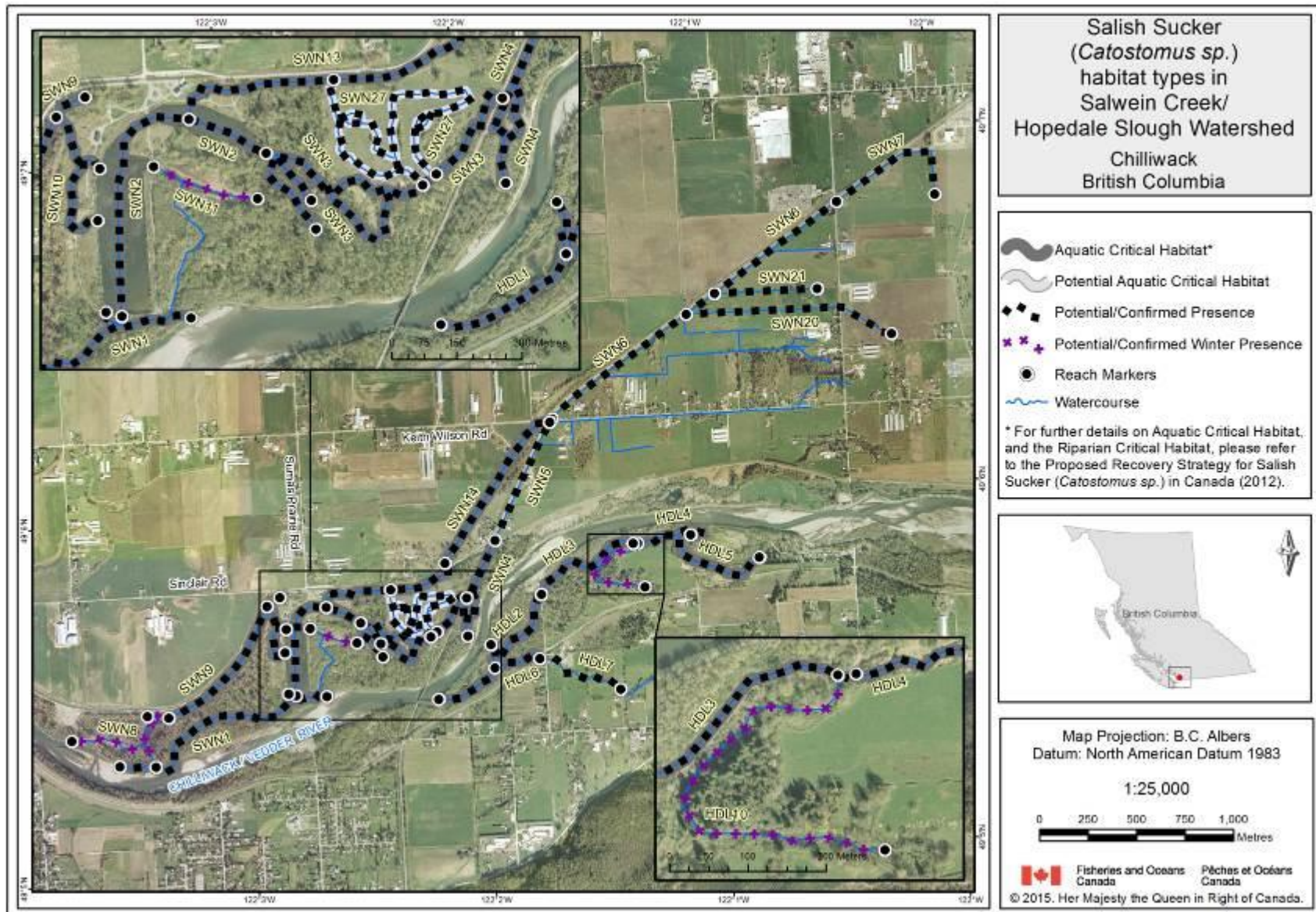

Figure A16. Habitat types for Salish Sucker stream reaches in the Salwein Creek/Hopedale Slough watershed.